

Motorschutzbügel  
MOTO GUZZI Stelvio

Artikel-Nr.:  
501.541 00 01 schwarz

Seitenkoffer  
Topcases  
Gepäckträger  
Lock it System  
Softbags  
Aluminiumkoffer  
Lederkoffer  
Schutzbügel  
Hauptständer  
Chopper-Parts  
Quad-Parts  
Accessoires



## Montage

Der Bausatz umfaßt die folgenden Teile:

Stück	Bestellnr.	Bezeichnung
1	706.505HB	Motorschutzbügel links
1	706.506HB	Motorschutzbügel rechts
1	706.507HB	Querbügel
2	150.938	Linsenkopfschraube M 8 x 20
2	151.009	Inbusschraube M 12 x 80
1	150.863	Inbusschraube M 10 x 20
2	150.810	U-Scheibe ø8,4
1	150.811	U-Scheibe ø10,5
2	150.010	U-Scheibe ø13
2	151.144	Stahldistanz ø20 x ø13 x 21





## Montage

### Vorbereitung:

**ACHTUNG:** Motor unterbauen, um ein Absenken zu verhindern.  
Bei der Montage des Querbügels müssen die Motorbefestigungsschrauben ersetzt werden !

### Tipp:

Schrauben sie alle Teile an und lassen sie die zugänglichen Schrauben etwas locker. Nachdem alles montiert ist, werden alle Schrauben auf das entsprechende Anzugsmoment angezogen. Dadurch wird sichergestellt, dass das Produkt spannungsfrei angebaut ist. Damit ist eine lange Lebensdauer sichergestellt !

### Befestigung des Querbügel links und rechts:

Dieser verläuft quer zur Fahrtrichtung unterhalb des Kühlers.  
Die Verschraubung erfolgt über der vorderen Motoraufhängung.  
Stahldistanz  $\varnothing 20 \times \varnothing 13 \times 21$  in die Rahmenhülse einstecken.  
Zur Befestigung des Querbügels die Inbusschrauben M12 x 80 mit U-Scheibe  $\varnothing 13$  verwenden.

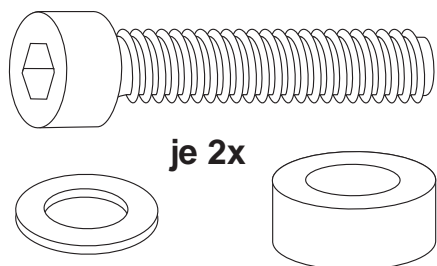

1

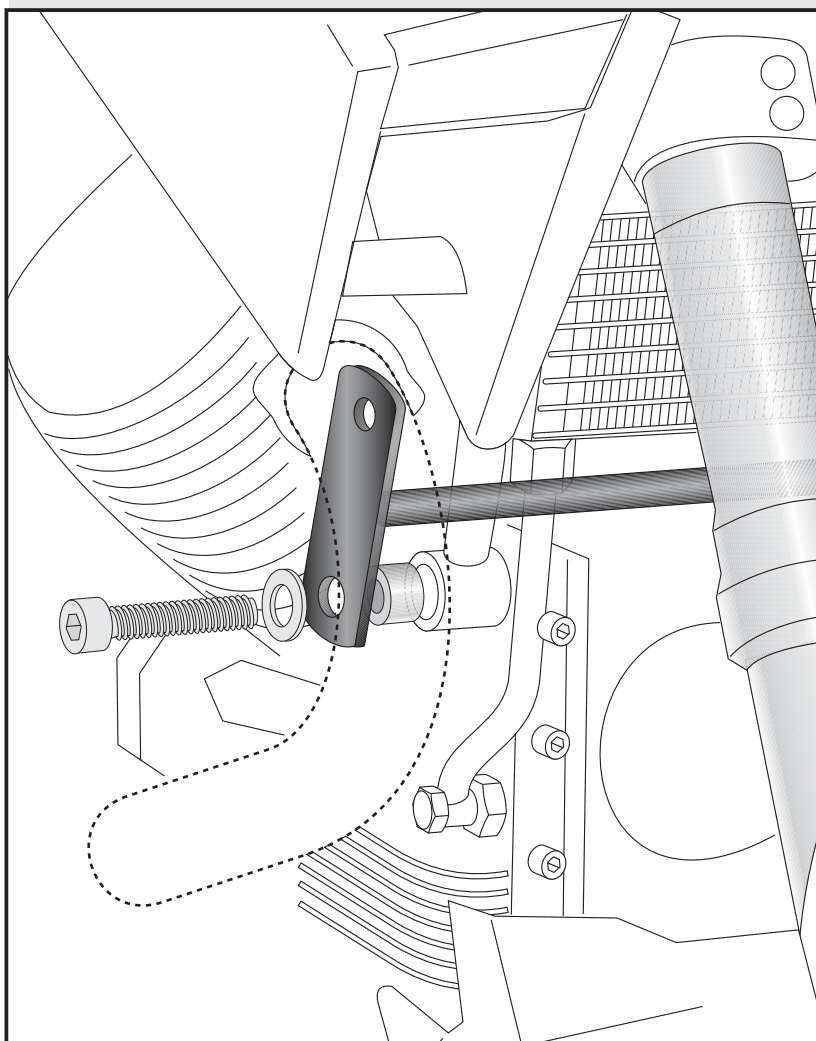

# Motorschutzbügel MOTO GUZZI Stelvio

Artikel-Nr.:  
501.541 00 01 schwarz

Seitenkoffer  
Topcases  
Gepäckträger  
Lock it System  
Softbags  
Aluminiumkoffer  
Lederkoffer  
Schutzbügel  
Hauptständer  
Chopper-Parts  
Quad-Parts  
Accessoires



## Montage

**2** Befestigung des Motorschutzbügels unten links und rechts: über dem Halteblech der Motorverkleidung. Zur leichteren Montage die Verkleidung demontieren. ① Rechts: zur Befestigung des Motorschutzbügels die Originalschrauben verwenden. ② Anschließend Verkleidung wieder anbringen. Links: oben die Inbusschraube M10 x 20 mit U-Scheibe  $\varnothing 10,5$  verwenden, unten die Originalschraube (Sechskant).

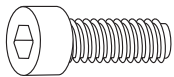

je 1x

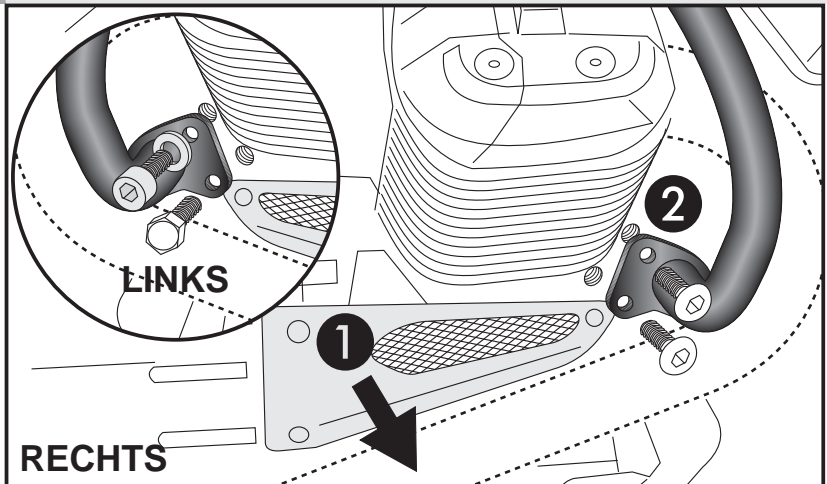

**3** Befestigung des Motorschutzbügels oben links und rechts: am zuvor montierten Querbügel. Zur Befestigung des Motorschutzbügels die Linsenkopfschraube M8 x 20 mit U-Scheibe  $\varnothing 8,4$  verwenden.

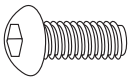

je 2x

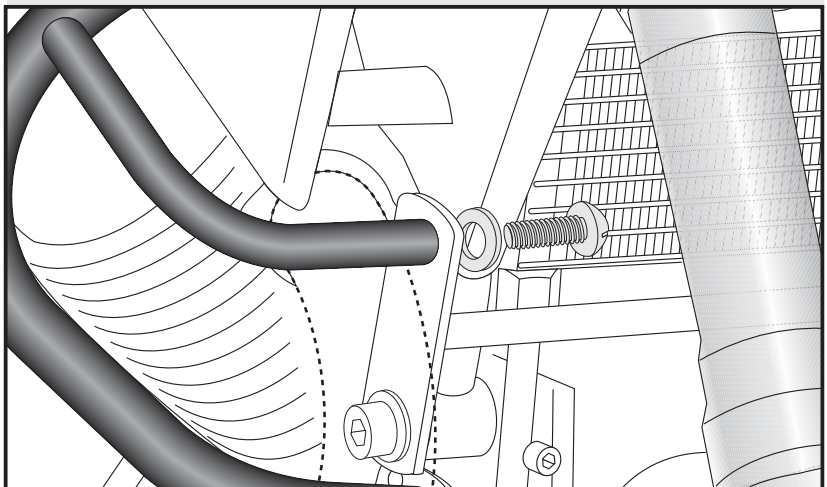

**Anzugsmomente des Motorradherstellers beachten!**  
**Nach der Montage alle Verschraubungen auf festen Sitz kontrollieren!**  
**Bitte beachten Sie unsere beigefügten Serviceinformationen.**

Als weiteres Zubehör lieferbar:

Kofferträger 650.541 00 01 schwarz - Lock it System, abnehmbar  
Gepäckbrücke 650.541 01 01 schwarz



Hepco & Becker GmbH  
Birkenstraße  
D-66989 Hühfroschen

Tel. 0049 (0) 6334 - 9216-0  
Fax 0049 (0) 6334 - 9216-80  
www.hepco-becker.de



Engine guard  
MOTO GUZZI Stelvio

Item-No.  
501.541 00 01 black

Side cases

Top cases

luggage frames

Lock it system

Softbags

Aluminium luggage

Leather luggage

Protection bars

Center stands

Chopper parts

Quad parts

Accessories



Assembling instructions

The kit includes the following parts:

Quant	item no.	description
1	706.505HB	engine guard left
1	706.506HB	engine guard right
1	706.507HB	bracing bow
2	150.938	fillsiter head screw M 8 x 20
2	151.009	allen screw M 12 x 80
1	150.863	allen screw M 10 x 20
2	150.810	washer ø8,4
1	150.811	washer ø10,5
2	150.010	washer ø13
2	151.144	steel spacer ø20 x ø13 x 21



Engine guard  
MOTO GUZZI Stelvio

Item-No.  
501.541 00 01 black

Side cases

Top cases

Luggage frames

Lock it system

Softbags

Aluminium luggage

Leather luggage

Protection bars

Center stands

Chopper parts

Quad parts

Accessories



## Assembling instructions

Preparing:

**NOTICE:**

While fastening the bracing bow, the screws which hold the engine, will be changed.  
Therefore it is necessary, to prevent sinking of the engine block  
- put something under the block to fix it's position.

Tip:

Fit all parts and screw on not too strong.  
After mounting all parts, the screws should be tightened to the torque specified.  
This guarantees, that the kit is mounted without tension.

Fastening of the bracing bow

left + right:

Position under the cooler at the front engine suspension.

First put steel spacer  $\varnothing 20 \times \varnothing 13 \times 21$  in the frame tube.

For fixing use allen screw M12 x 80 and washer  $\varnothing 13$ .

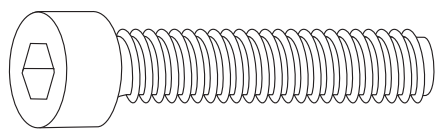

each 2x



1

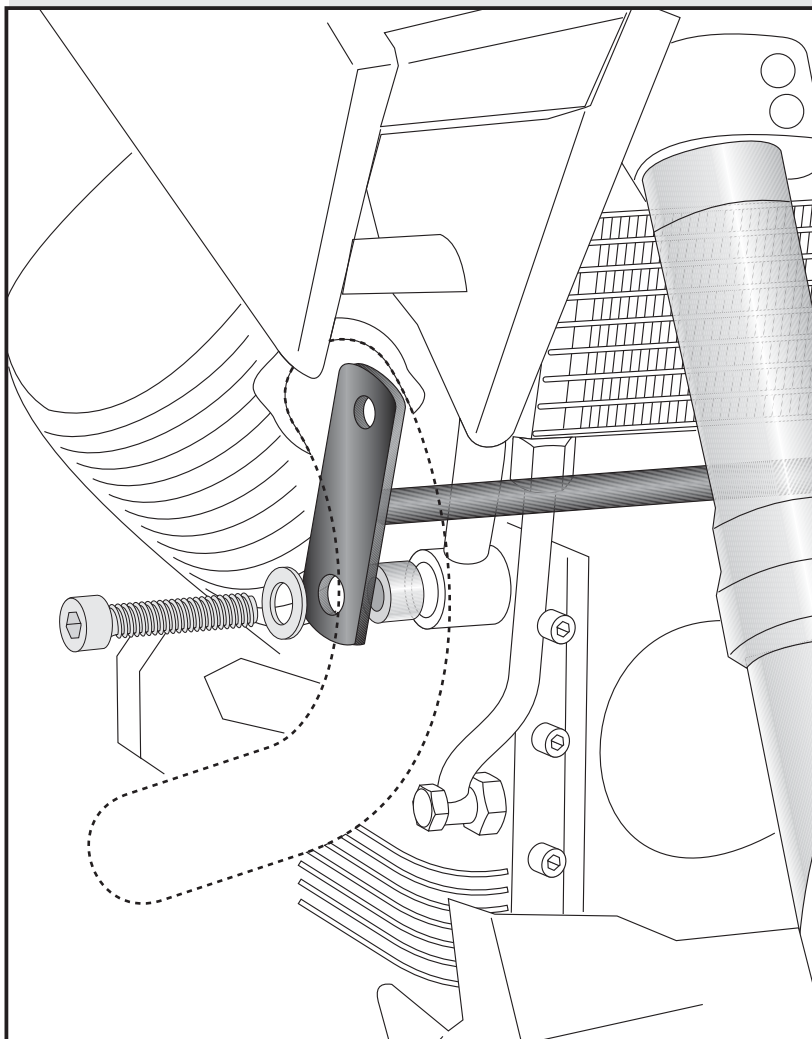

Luggage ideas.

2

Engine guard  
MOTO GUZZI Stelvio

Item-No.  
501.541 00 01 black

Side cases  
Top cases  
luggage frames  
Lock it system  
Softbags  
Aluminium luggage  
Leather luggage  
Protection bars  
Center stands  
Chopper parts  
Quad parts  
Accessories



## Assembling instructions

### Fastening of crash bar bottom left+right:

Dismantle the plastic cover ①  
Right side: to fix the crash bar, use original screws. ②  
After that, mount the plastic cover.  
Left side: top fixing point: allen screw M10 x 20 and washer  $\varnothing 10,5$ .  
Bottom fixing point: use original screw.

2

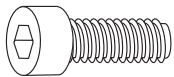
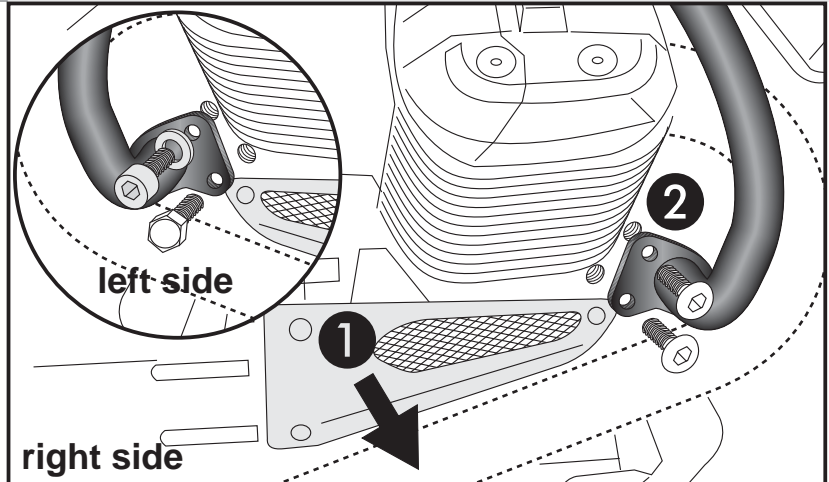

each 1x

### Fastening of crash bar top left+right:

At the bracing bow with filister head screws M8 x 20 and washer  $\varnothing 8,4$ .

3

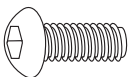
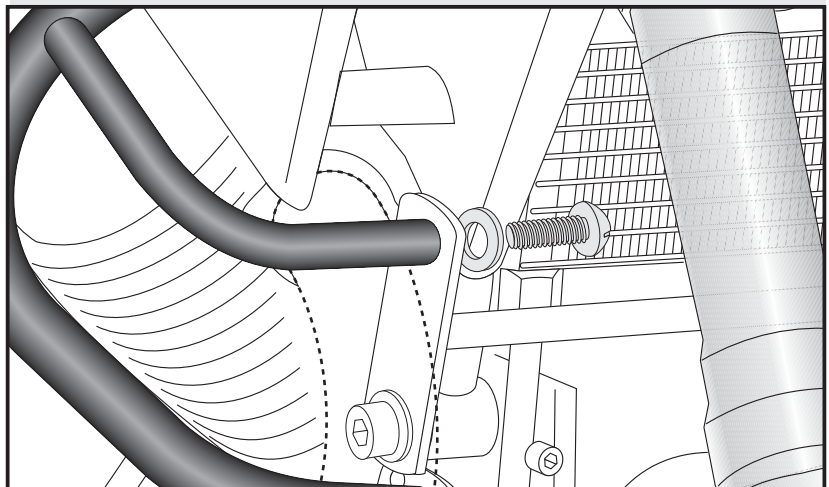

each 2x

**Control all screw connections after the assembling for tightness!**

**Please notice our enclosed service information.**

**All screws, bots und nuts should be checked after driving the first 50 km to ensure that all are tightened to the proper torque.**

Also available:

Side carrier            650.541 00 01 black, "Lock it System" (removable)

Rear rack             650.541 01 01 black



Hepco & Becker GmbH  
Birkenstraße  
D-66989 HÖHFRÖSCHEN

Tel. 0049 (0) 6334 - 9216-0  
Fax 0049 (0) 6334 - 9216-80  
www.hepco-becker.de